



# EXTREME SERIES™

POWERED BY **LiftMaster**



## CLOPAY® EXTREME™ SERIES HIGH PERFORMANCE SECTIONAL DOOR SYSTEM

The Clipay® Extreme™ Series High Performance Sectional Door System boasts an average opening speed of 24" per second, allowing productivity to flourish while also delivering the aesthetic you're looking for. Tandem nylon rollers improve roller life and reduce running noise for smooth, quiet operation while safety stays top of mind with enhanced features such as 3' of light curtain protection, a cable management system and standard cable tension monitors.

[clipaycommercial.com](http://clipaycommercial.com)



# EXTREME™ SERIES AVAILABILITY

## architectural series

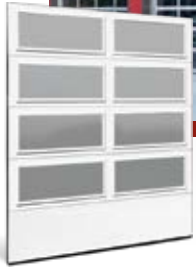

EX904, EX904U,  
EX3728, EX3729, EX3708,  
EX3709, EX3208, EX3209,  
EX3158, EX3159,

## energy series with intellicore



EX3724, EX3722,  
EX3723, EX3721, EX3720,  
EX3717, EX3718, EX3715

## energy series



EX3200, EX3213,  
EX3211, EX3220, EX3150

For specific model information visit [www.clopaycommercial.com](http://www.clopaycommercial.com)

## HARDWARE FEATURES



Double end stiles to improve hinge longevity



Long stem tandem rollers provide longer roller life and quieter door operation



Cable snubbers to keep tension on the cable to prevent it from coming off of the drum



Pusher springs are used to prevent cable slack (required for standard lift track)



50,000 cycle springs standard\*

## STANDARD SPECIFICATIONS

Max Width	16'2"
Max Height	14'0"
Max Door Weight	1,000 lbs
Upward Travel	24" per second
Downward Travel	15" per second
Stiles	Double end stiles (standard)
Glazing Available	Tempered, insulated tempered, acrylic and polygal
Springs	50,000 cycle standard* (Max cycles available on a single shaft line)
Track Size	2" angle mount track standard 3" track where applicable
Track Type	Standard lift, high lift and full vertical lift

\*Cycles can vary depending on door configuration.



## WINDCODE®

Design pressures (DP) up to 36 PSF depending on door size, configuration and exposure. Models tested 50% greater than DP.



# CLOPAY® EXTREME™ SERIES OPERATOR POWERED BY LIFTMASTER®

The Extreme™ Series High Performance Sectional Door System features a direct drive operator with an opening speed of 24" per second and up to 600 cycles per day. The display's easy-to-read user interface provides ease of limit-setting at floor level and can connect to the operator via Wi-Fi to myQ® Facility.

## SAFETY FEATURES



UL325 approved light curtain that reverses the door's downward motion when the beam is broken



Cable tension monitor that mitigates door operation when cable slackening occurs



Optional wireless bottom safety edge that reverses the door's downward motion upon contact with an object



## PERFORMANCE REQUIREMENTS

Average Opening Speed	24" per second
Average Closing Speed	15" per second
Daily Duty Cycles	600 cycles/day
Max. Door Weight	1,000 lbs.
Warranted Cycles	600 cycles per day over 2-year warranty period
Drive System	Direct drive

## INSTALLATION AND COMMISSIONING

Motor Design	1.25 HP configuration serving single phase 115V/230V and 3-phase 230V configurations; 3-phase 460/575V available with accessory transformer
Wall Controller	Separation of low and high voltage wiring – includes functionality of 3-button station, PLUS setting door profile, programming limits, diagnostics
Programming	Complete the following programming at floor level: set limits; choose door profiles for speed; set operating modes; select photo entrapment devices
Display	Provides textual status indications including: <ul style="list-style-type: none"> <li>Absolute cycle count</li> <li>Service cycle count</li> <li>Diagnostics messages</li> <li>Door/operator status</li> </ul>
Cycle Counter	Re-settable cycle counter via the wall controller and/or through myQ® Facility
Limit Setting	Simple electronic push-button setup via the wall controller

## CONNECTIVITY

Wi-Fi Connectivity	Connectable solution via built-in Wi-Fi
myQ® Facility Subscription	First year myQ® Facility subscription included
Over-the-Air Updates	Standard via Wi-Fi
Service Cycle Count	On wall controller display; standard via myQ® Facility
Lifetime Cycle Count	On wall controller display; standard via myQ® Facility
Remote Diagnostics	On wall controller display; standard via myQ® Facility

# TRACK AND MOUNTING OPTIONS

## STANDARD RADIUS

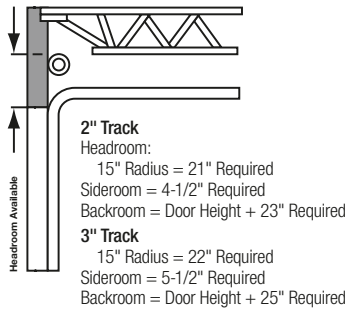

## HIGH LIFT

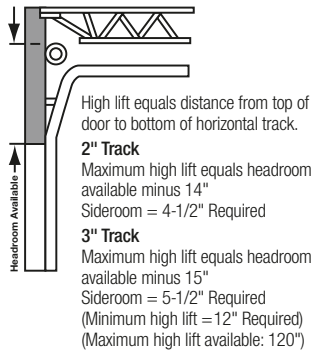

## VERTICAL LIFT

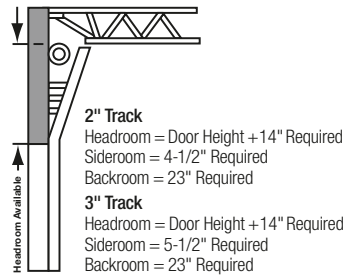

*All track types: 19-3/4" of sideroom on the operator side only is recommended to slide the operator onto the installed extended shaft. Spacing between track and door is to be 3/4".*

## VERTICAL TRACK MOUNTING OPTIONS

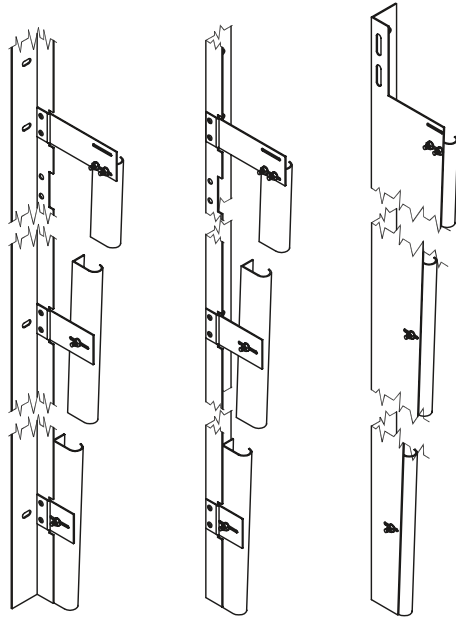

**2" OR 3"  
CLIP MOUNT  
CONTINUOUS  
ANGLE**

**2" OR 3"  
CLIP MOUNT  
REVERSE  
ANGLE**

**3" FULL TAPERED  
REVERSE OR  
CONTINUOUS  
ANGLE**



For more information on these and other Clopay products, visit [clopaycommercial.com](http://clopaycommercial.com). Architects and specifiers, visit [architectdoorhelp.com](http://architectdoorhelp.com).

